

GN Electronics Inc.

Quanta-Flame Scanner Model: 5004-01



Description

The 5004-01-scanner is an ultraviolet (UV) sensor for monitoring gas or oil flames. The Quanta-Flame flame safeguard checks the scanner for proper operation at the beginning and end of each flame cycle. It comes with a 6 foot shielded flexible cable with a military style connector, which plugs into the scanner base for quick and easy servicing

The UV tube is made of quartz and is filled with a gas that ionizes when struck by UV radiation from the flame. In the absence of UV radiation, the gas acts as an insulator between two electrodes, which are mounted inside the tube. A high voltage energizes these electrodes continuously. During combustion, UV radiation ionizes the gas, causing current pulses to flow between the electrodes.

These current pulses result in a flame signal, which is transmitted to the amplifier in the control, where it is processed to energize or hold in the flame relay.

Application

UV scanners are recommended for detecting flames from standard fuel gases, some waste gases and light oil fuels such as No. 2 oil. Flames from heavier oils can be detected with UV scanners but the unburned fuel shroud and/or atomization shroud can block passage of the UV from the flame zone to the UV tube, causing nuisance burner/boiler trips. Infrared detection is recommended for fuel oil heavier than No. 2, and some installations where waste gases are burned together with natural gas as a main flame.

SPECIFICATIONS

Operating Voltage: 300 VDC \pm 25 VDC

Operating Current: 2 mA Max

Sensitivity: 120 CPS

Background Noise: < 20 CPM

Supply Wiring: 122 cm (6 ft.) shielded instrument cable with two #18 AWG conductors

Max Operating Distance: 200 feet total wire length

Ambient Temperature: -40° to $+100^{\circ}\text{C}$ (-40° to 212°F) (5004-01)

-20° to $+60^{\circ}\text{C}$ (0° to 140°F) (5004-01 RA)

Shipping Weight: 1.4 kilograms (3 lbs.)

Spectral Range: 180 to 250 nanometers

IMPORTANT NOTE

A qualified technician must only perform any installation of this or other burner control devices. Incorrect installation can result faulty signal indications.

9958 North Alpine Road Suite 104 Machesney Park IL 61115

Phone: 815-637-8624 Fax: 815-637-8626

Web Page at: www.gnelectronics.com

GN Electronics Inc.

INSTALLATION OF UV SCANNERS

Note: Where possible, obtain the Burner Manufacturer's Instructions for mounting the scanner. This information is available for most standard burners. The scanner mounting should comply with the following general instructions:

1. Install the scanner on a standard 1/2 in. NPS pipe whose position is rigidly fixed. The sight pipe must permit an unobstructed view of the pilot and/or main flame, and both pilot and main flames must completely cover the scanner field of view. Please note that oil and gas flames radiate more ultraviolet energy from the base of the flame than from further out in the flame. This fact should be considered when installing the scanner sight pipe.
2. Position the UV scanner within 48 inches of the flame to be monitored.
3. Since the radiated energy from an electric spark igniter is very rich in the UV region, the field of view should be aimed so that it does not see an electric spark igniter or any reflector that is close to the spark to prevent spark pickup by the UV detector.
4. The scanner must not be dropped or otherwise treated with force. This is a fragile device and will break if improperly handled. Scanner is to be hand tighten only.
DO NOT USE A WRENCH ON THESE
5. Avoid running the scanner conduit in close proximity to high-energy ignition wires.
6. Avoid running the scanner cables or conduit in close proximity to hot surfaces at the burner.
7. Close all pilot and main fuel valves. Operate the control through a burner startup cycle to determine that ignition spark cannot be detected. Burner will not ignite if spark is detected.
8. Smoke or unburned combustion gases absorb ultraviolet radiation. In negative pressure combustion chamber installations, a small hole drilled in the scanner sight pipe will assist in keeping the pipe clean and free of smoke. For positive pressure furnaces, provide clean air to pressurize the sight pipe, if necessary.

WARNINGS:

- **When installing or replacing UV scanners, a minimum pilot turndown test on pilot ignited burners and a spark pickup test on all burners must be performed. This test assures that the flame detector will not detect a pilot flame too small to reliably light off the main flame. The test should be made on every new installation and following any repositioning of the flame detector. A qualified technician must perform the Minimum Pilot Turn down test.**
- **The leads from the scanner to the control must be shielded to prevent electrical noise from generating a false flame signal to the control. The unprotected leads must be run in electrical conduit in order to eliminate pickup of electrical noise, which could present an unsafe condition.**
- **The scanner must not sight the ignition spark directly or any parts of the burner that can reflect the spark back to the scanner. The scanner must not see a pilot flame that is too small to reliably ignite the main flame. Incorrect sensor installation may cause the sensor to generate a false flame signal. This can cause unburned fuel to collect in the combustion chamber, resulting in explosions, injuries, and property damage. Be certain that the flame sensor detects only the pilot and main flames, not glowing refractory or burner parts.**

GN Electronics Inc.

WIRING – UV SCANNERS

Sensor wiring must be routed a sufficient distance from ignition and other high voltage wiring to avoid electrical interference.

If sensor wiring is to extend beyond the factory-supplied cable length, use #14 to #18 AWG wire suitable for 75°C (167°F) and 600 volt insulation, and run each pair of leads in its own conduit or shielded cable.

Multiple shielded cables can be run in a common conduit, but only on short distances.

Depending on field conditions, sensor wiring can be up to 76.25 m (250 ft.) for UV scanners.

For extended scanner wiring up to 500 feet, or for shorter lengths to reduce signal loss, use a shielded wire (Belden 8254, RG-62/U coaxial cable, or equal) for each scanner wire. The ends of the shielding must be taped and not grounded.

High voltage ignition wiring should not be installed in the same conduit with flame detector wires.

MAINTENANCE

Ultraviolet Scanners

The viewing area of the scanner must be kept clean. Even a small amount of contamination on the lens will reduce the flame signal reaching the detector by a measurable amount. Wipe the viewing area routinely using a soft cloth dampened with concentrated detergent, then wipe dry.

Flame Signal Strength

Routine observation of the flame signal strength will forewarn any deterioration in the capability of the flame detector or its application.

Periodic Safety Check

It is recommended that a procedure be established to test the complete flame safeguard system at least once a month. This test should verify the proper operation of all limit switches and safety interlocks as well as flame failure protection and fuel safety shutoff valve tightness.

Rotation

It is recommended that control and scanner units purchased as spares be installed periodically to ensure proper operation.

GN Electronics Inc.

Wiring Diagram (5004-890)

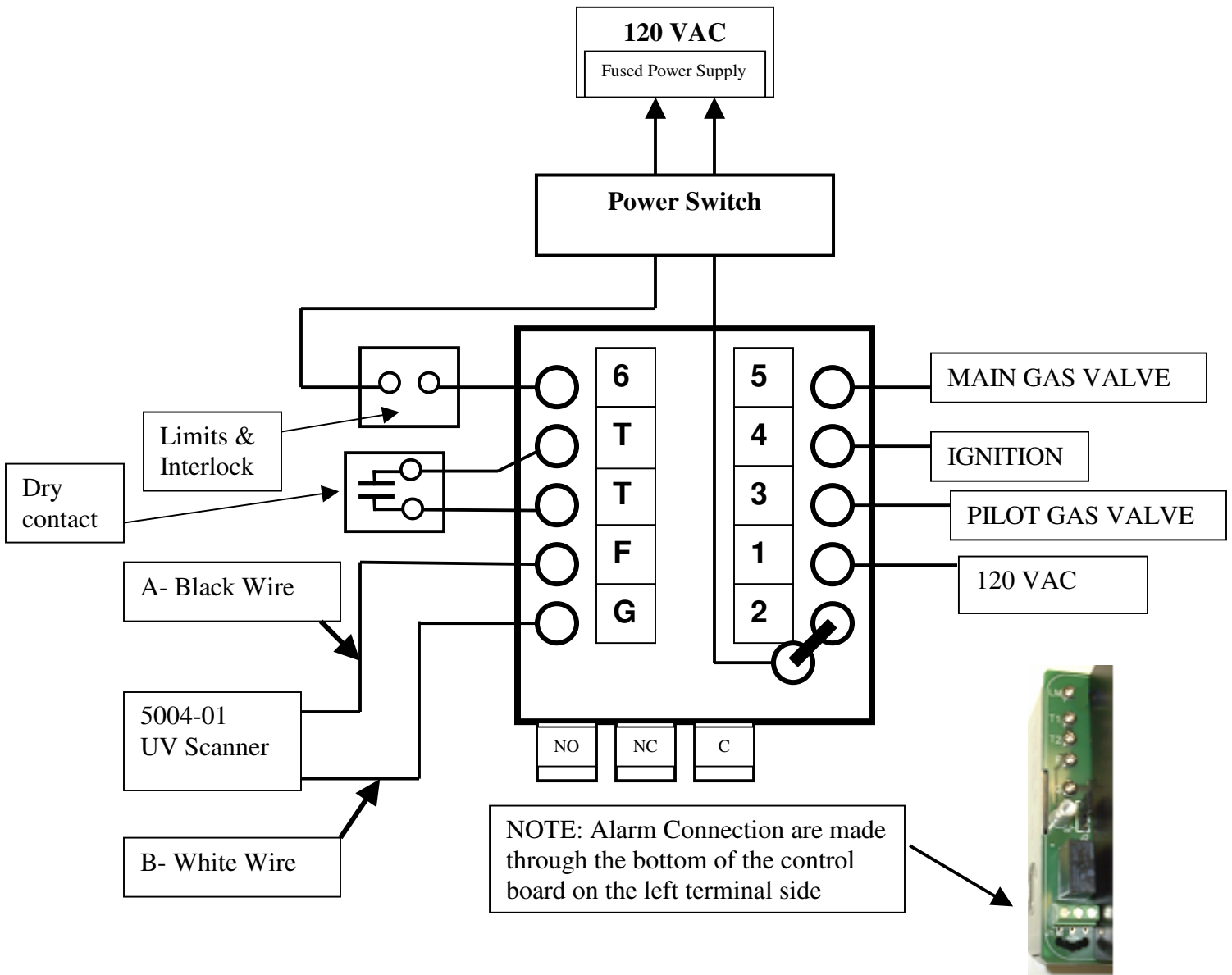

GN Electronics Inc.

Wiring Diagram (5004-M,P,N)

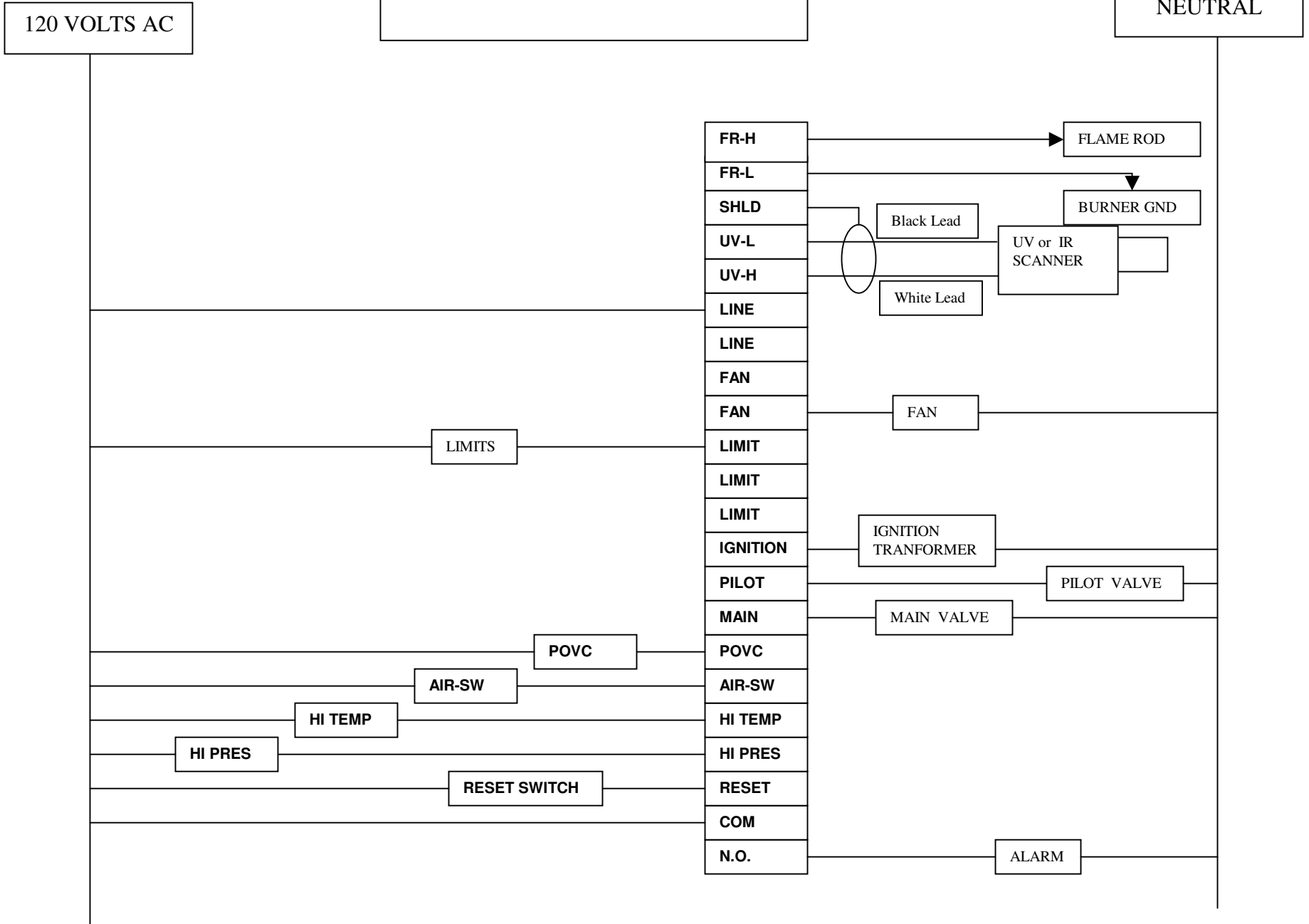

GN Electronics Inc.

WARRANTIES

The 5004-01 is warranted for one (1) year from the date of delivery. GN Electronics standards terms and conditions apply. Defective units should be returned to G N Electronics. Controls should be well packed in a suitable container encased in appropriate stuffing.

All products should **be shipped prepaid to:**

**G N Electronics Inc
9958 N. Alpine Rd Suite #104
Machesney Park, IL 61115**

**Tel: (815) 637-8624
Fax: (815) 637-8626**

www.gnelectronics.com